

Inverting Subsumption for Constructive Reasoning

Simona Colucci, Francesco M. Donini

DISUCOM, Università della Tuscia, Viterbo, Italy

Abstract. We present a Logic Programming prototype implementation, working as proof-of-concept for a unified strategy proposed in our past research to solve several non-standard reasoning problems in Description Logics (DLs), denoted by *Constructive Reasoning*. In order to prove both the problem-independence and the logic-independence of the adopted approach, the prototype is focused on the solution of three different problems — namely Least Common Subsumer, Concept Abduction and Concept Difference — and two different, though simple and endowed with structural subsumption, DLs, *i.e.*, \mathcal{EL} and \mathcal{ALN} . Accordingly to the implemented strategy, problems are formalized as conjunction of both subsumption and non-subsumption statements, causing the whole prototype to rely on a Prolog program solving subsumption. The program is built around a predicate, which on the one hand checks for the existence of subsumption relations between ground elements, providing boolean answers, and on the other hand, if inverted, exploits Prolog built-in unification to enumerate variable values making subsumption true between concept terms containing concept variables.

1 Introduction

The power of knowledge lays in its ability to enhance the production of unknown information, through management strategies whose significance increases with the level of novelty introduced by provided results.

In past knowledge management literature, in fact, interest has been given to the proposal of special purpose inferences allowing for exploiting as much as possible the informative content achieved through knowledge representation effort. To this aim, several non-standard reasoning services have been proposed and continue to be investigated to cope with different representation or inference needs. The most relevant services we may cite are explanation [16], interpolation [18], concept abduction [12], concept contraction [11], concept unification [5], concept difference [19], concept similarity [8], concept rewriting [3], least common subsumer [7], most specific concept [1], knowledge base completion [6], forgetting or uniform interpolation [14].

We notice that the crucial role of non-standard reasoning in the process of capturing unexpected sources of information has been stressed also in research fields apparently far from knowledge representation [15].

Moreover, recent Description Logics (DLs) literature has shown interest for easily tractable, even though not very expressive, sub-languages, like \mathcal{EL} [17, 4, 13].

In our past research [10] we proposed an integrated approach and solving strategy for dealing with several different non-standard inferences. The framework, presented as independent of the DL adopted for knowledge representation, takes a *constructive*

reasoning perspective on problem solving: most inferences are in the form “Find one or more concept(s) C such that {sentence involving C }“ and the proposed framework aims at building such C .

In order to show the feasibility of such an integrated constructive reasoning approach, we here present a prototype implementation in Logic Programming solving Least Common Subsumer, Concept Difference and Concept Abduction in the simple DLs \mathcal{EL} , \mathcal{ALN} , both endowed with structural subsumption algorithms.

Though still inefficient at this stage, the prototype works as proof-of-concept for the integrated solution framework. It exploits the property of our approach according to which most non-standard reasoning problems may be formalized as conjunction of both subsumption and non-subsumption statements and therefore relies on a Prolog program solving subsumption, built around a main predicate called either *subs_el* or *subs_aln*, depending on the adopted \mathcal{DL} . In particular, we show how to invert the *subs* predicate (either *subs_el* or *subs_aln*), so that not only it can check subsumption between ground elements (providing boolean answers), but it can also exploit Prolog built-in unification to enumerate variable values making subsumption true between concept terms containing concept variables. The approach takes a generate-and-test strategy.

In the next section, we shortly recall how to formalize the three problems in the integrated framework. Then, we describe the architecture of the prototype implementing the solving strategy in Section 3, before delving into details of subsumption program, on which the whole prototype relies, in Section 4. We show how to query the presented prototype in Section 5, and, finally, close the paper with discussions and future work.

2 Background Framework

The approach presented in our past research [10] models each of the problems at hand as Optimal Solution Problem, whose definition exploits specific second order formulas, written as conjunction of concept subsumptions and non-subsumptions, in the following form:

$$\Gamma = (C_1 \sqsubseteq D_1) \wedge \cdots \wedge (C_\ell \sqsubseteq D_\ell) \wedge (C_{\ell+1} \not\sqsubseteq D_{\ell+1}) \wedge \cdots \wedge (C_m \not\sqsubseteq D_m) \quad (1)$$

In Formula (1), $C_1, \dots, C_m, D_1, \dots, D_m \in \mathcal{DL}$ denote concept terms containing concept variables X_0, X_1, \dots, X_n . We say that Γ is satisfiable in DL iff there exists a substitution $\sigma = X_0 \mapsto E_0, \dots, X_n \mapsto E_n$ such that $\sigma(\Gamma)$ is true (i.e., each subsumption and non-subsumption statement in (1) is true). If Γ is satisfiable in \mathcal{DL} then \mathcal{E} is called a **solution** for Γ and the set of solutions for Γ is defined as:

$$SOL(\Gamma) = \{\mathcal{E} = \langle E_0, \dots, E_n \rangle \mid \mathcal{E} \text{ is a solution for } \Gamma\}$$

Definition 1 (OSP). An Optimal Solution Problem (OSP) \mathbf{P} is a pair $\langle \Gamma, \prec \rangle$, where Γ is a formula of the form (1) and \prec is a preorder over $SOL(\Gamma)$. A solution to \mathbf{P} is a concept tuple \mathcal{E} such that both $\mathcal{E} \in SOL(\Gamma)$ and there is no $\mathcal{E}' \in SOL(\Gamma)$ with $\mathcal{E}' \prec \mathcal{E}$.

2.1 Non-standard Services in DLs as OSPs

In the following, we recall how to model the three investigated problems as OSP. Aiming at a fixpoint computation for solving each of the problems below, a greatest element (*i.e.*, a least preferred one) w.r.t. \prec is provided, which could be used to start the iteration of an inflationary operator.

Least Common Subsumer

Definition 2. [9] *Let C_1 and C_2 be two concepts. The Least Common Subsumer (LCS) of C_1, C_2 is the least element w.r.t. \sqsubseteq of the set of concepts which are Common Subsumers of C_1, C_2 and is unique up to equivalence.*

Common subsumers of C_1, C_2 satisfy the formula of the form (1):

$$\Gamma_{LCS} = (C_1 \sqsubseteq X) \wedge (C_2 \sqsubseteq X)$$

Then, the LCS problem can be expressed by the OSP $LCS = \langle \Gamma_{LCS}, \sqsupseteq \rangle$. We note that \top is always a solution of Γ_{LCS} which is a greatest element w.r.t. \sqsupseteq .

Concept Difference Following the algebraic approaches adopted in classical information retrieval, Concept Difference [19] was introduced as a way to measure concept similarity.

Definition 3. [19] *Let C and D be two concepts such that $C \sqsubseteq D$. The Concept Difference $C - D$ is defined by $\max_{\sqsubseteq} \{B \in \mathcal{DL} \text{ such that } D \sqcap B \equiv C\}$.*

We can define the following formula of the form (1):

$$\Gamma_{DIFF} = (C \sqsubseteq (D \sqcap X)) \wedge ((D \sqcap X) \sqsubseteq C)$$

Such a definition causes Concept Difference to be modeled as the OSP $DIFF = \langle \Gamma_{DIFF}, \sqsupseteq \rangle$. We recall that, in spite of its name, a Concept Difference problem may have several solutions [19]. Note that a greatest solution for Γ_{DIFF} w.r.t. \sqsupseteq is C itself.

Concept Abduction Concept Abduction is a straight adaptation of Propositional Abduction.

Definition 4. [12] *Let C, D , be two concepts in \mathcal{DL} , both C and D satisfiable. A Concept Abduction Problem (CAP) is finding a concept $H \in \mathcal{DL}$ such that $C \sqcap H \not\sqsubseteq \perp$, and $C \sqcap H \sqsubseteq D$.*

Every solution H of a CAP satisfies the formula

$$\Gamma_{ABD} = (C \sqcap X \not\sqsubseteq \perp) \wedge (C \sqcap X \sqsubseteq D)$$

The preference relation for evaluating solutions is subsumption-maximality, since less specific solutions should be preferred because they hypothesize the least. According to the proposed framework, we can model Subsumption-maximal Concept Abduction as $ABD = \langle \Gamma_{ABD}, \sqsupseteq \rangle$. Note that a greatest—*i.e.*, most specific—solution of ABD w.r.t. \sqsupseteq is D , if $C \sqcap D$ is a satisfiable concept (if it is not, then ABD has no solution at all [12, Prop.1]).

2.2 Optimality by Fixpoint

Optimal solutions w.r.t. a preorder might be reached by iterating an inflationary operator. We now specialize the definition of inflationary operators and fixpoints to our setting.

Definition 5 (Inflationary operators and fixpoints). *Given an OSP $\mathbf{P} = \langle \Gamma, \prec \rangle$, we say that the operator $b_{\mathbf{P}} : SOL(\Gamma) \rightarrow SOL(\Gamma)$ (for **better**) is inflationary if for every $\mathcal{E} \in SOL(\Gamma)$, it holds that $b_{\mathbf{P}}(\mathcal{E}) \prec \mathcal{E}$ if \mathcal{E} is not a least element of \prec , $b_{\mathbf{P}}(\mathcal{E}) = \mathcal{E}$ otherwise. In the latter case, we say that \mathcal{E} is a fixpoint of $b_{\mathbf{P}}$.*

Intuitively, $b_{\mathbf{P}}(\mathcal{E})$ is a solution better than \mathcal{E} w.r.t. \prec , if such a solution exists, otherwise a fixpoint has been reached, and such a fixpoint is a solution to \mathbf{P} . Being $b_{\mathbf{P}}$ inflationary, a fixpoint is always reached—possibly in an infinite number of steps—by the following induction: starting from a solution \mathcal{E} , let

$$\begin{aligned}\mathcal{E}_0 &= \mathcal{E} \\ \mathcal{E}_{i+1} &= b_{\mathbf{P}}(\mathcal{E}_i) \text{ for } i = 0, 1, 2, \dots\end{aligned}$$

Then, there exists a limit ordinal λ such that \mathcal{E}_λ is a fixpoint of $b_{\mathbf{P}}$. For each of the previous non-standard reasoning services, we highlighted a greatest solution $\mathcal{E} \in SOL(\Gamma)$ which this iteration can start from. Obviously, when \prec is well-founded (in particular, when $SOL(\Gamma)$ is finite) the fixpoint is reached in a finite number of steps, but the general conditions for well-foundedness of \prec are not known, and out of the scope of this paper. However, also when after n iterations \mathcal{E}_n is not a fixpoint, one can stop and consider \mathcal{E}_n as an approximation of an optimal solution, since $\mathcal{E}_{i+1} \prec \mathcal{E}_i$ for every $i = 0, \dots, n$. In this sense, our method can be used as an anytime approximation.

Note also that the Tarski-Knaster results about uniqueness of the least fixpoint for a monotone operator are not applicable in this setting, first of all, because $b_{\mathbf{P}}$ is not monotone, and secondly because there can be more than one minimal fixpoint: in fact, it is known that for \mathcal{ALN} , both Concept Difference and Concept Abduction admit more than one solution.

We stress the fact that we are *not* proving here that every instance of Formula (1) can be solved by this method. For instance, deciding whether a formula of the form (1) is satisfiable is an open problem for \mathcal{ALN} , to the best of our knowledge. In this paper we address particular cases of (1), corresponding to known non-standard inferences, for which a solution is always known to exist.

It is interesting to observe that such particular cases are similar to *matching* problems [2], in that variables appear only on one side of each subsumption and non-subsumption statement.

3 Prototype Architecture

In the following, we present a prototype Logic Programming system implementing the above mentioned approach to non-standard inference [10]. The system has been developed exploiting the integrated environment provided by SWI-Prolog¹ (Multi-threaded, 32 bits, Version 5.6.64) and follows the modular architecture depicted in Figure 1.

¹ <http://www.swi-prolog.org/>

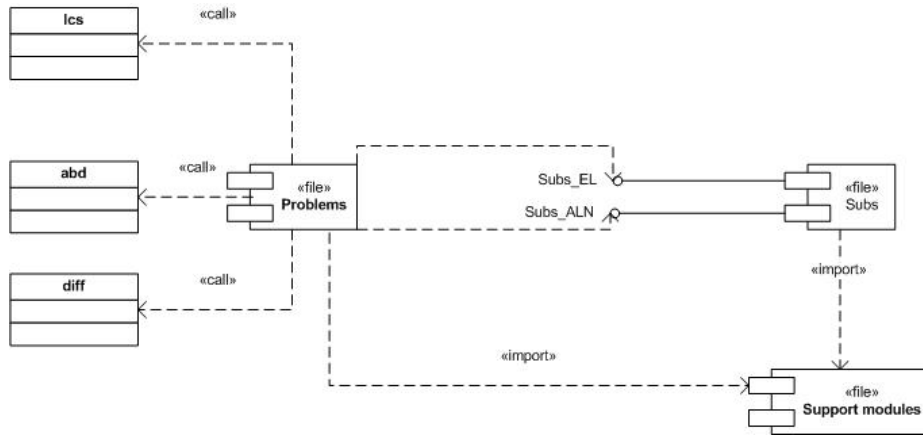

Fig. 1. Prototype Architecture

The system design has been focused on proving main distinguishing features of our approach: the generality and the independence of the adopted DL (within a given subset) of non-standard inferences solving strategy. In particular, the prototype here presented is devoted to the solution of three different reasoning services, namely Least Common Subsumer, Concept Difference and Concept Abduction, in \mathcal{EL} and \mathcal{ALN} .²

Coherently with the strategy introduced so far, the prototype searches for solutions for the system of the OSP modeling the non-standard inference need at hand. It is easy to notice that, therefore, the whole approach relies on the logic rules formalizing structural subsumption, which is at the basis of each formula to be solved.

The crucial role of subsumption affects the system architecture in Figure 1, whose main components are described below:

- **Subs** is the central component, which implements a recursive algorithm solving subsumption between concept descriptions; such a module is designed to provide one interface for each DL adopted to model the problem: the current prototype allows for solving subsumption in \mathcal{EL} and \mathcal{ALN} .
- **Problems** is the component implementing OSP solving algorithms: the current prototype allows for solving Least Common Subsumer (**ics**), Concept Difference (**diff**) and Concept Abduction (**abd**), but **Problems** may be extended to include further services. It is noteworthy how, depending on the DL adopted to model the problem, a different subsumption interface, either **subs_EL** or **subs_ALN**, is invoked.
- **Support Modules** includes clauses supporting the performance of subsumption and inferences included in Problems, but related to sorts of information processing outside the core solving algorithms, such as \mathcal{ALN} concept normalization in Concept Centered Normal Form and special purpose lists manipulation.

² See <http://dl.dropbox.com/u/28260263/DL2012exe.rar> for an executable version of the prototype.

4 Inverting Subsumption

In order to show the prototype implementing the solving strategy detailed so far, we refer to Least Common Subsumer computation, solved by the Prolog code fragment in the following, excerpted from **Problems** module.

```
1  :-use_module('subs_el').
2  :-use_module('subs_aln').
3  :-use_module('support_modules').
4  :-use_module('normalization').

5  problem(lcs,C,D,Result,DL):- lcs(C,D,Result,DL).
6  problem(abd,C,D,Result,DL):- abd(C,D,Result,DL).
7  problem(diff,C,D,Result,DL):- diff(C,D,Result,DL).

8  lcs(C1, C2, LN, DL) :-
9      manage_concept(C1, C1N, DL),
10     manage_concept(C2, C2N, DL),
11     find_lcs(C1N, C2N, [top], L, DL),
12     normalization_top(L, LN).

13 find_lcs(C1, C2, L1, L3, DL) :-
14     decorate(L1, L2),
15     better_lcs(C1, C2, L1, L2, DL), !,
16     find_lcs(C1, C2, L2, L3, DL).
17 find_lcs(C1, C2, L1, L1, _).

18 decorate(C,C0):- list(C,CL),select(some(R,D),CL,Rest),
19     decorate(D,DL),append(Rest,[some(R, DL)], C0).
20 decorate(C,C0):- list(C,CL), append(CL,[X0],C0).

21 better_lcs(C1, C2, L1, L2, el):-
22     subs_el(C1, L2),
23     subs_el(C2, L2),
24     not(subs_el(L1, L2)).

25 better_lcs(C1, C2, L1, L2, aln):-
26     computeMaxAtLeast(C1,Max3),
27     computeMaxAtLeast(C2,Max4),
28     MaxL is max(Max3,Max4),
29     computeMaxAtMost(C1,Max1),
30     computeMaxAtMost(C2,Max2),
31     MaxM is max(Max1,Max2),
32     subs_aln(C1, L2, MaxL, MaxM),
33     subs_aln(C2, L2, MaxL, MaxM),
34     not(subs_aln(L1, L2, MaxL, MaxM)).
```

We shortly recall that the shared strategy we proposed relies on the solution of an **Optimal Solution Problem** in which we search for solutions which are optimal w.r.t. a given preorder, by incrementally trying to *find* solutions which are *better* than the one at hand, till a best one is reached.

In order to compute the Least Common Subsumer LN of two concepts, C_1 and C_2 in a DL (see line 8), we need to incrementally construct a concept which subsumes both C_1 and C_2 , and is optimal w.r.t. subsumption minimality (in fact, LN must be the most specific common subsumer of C_1 and C_2). To this aim, we start considering the trivial, subsumption maximal, solution, $L_1 = \top$ (line 11) and recursively try to *find* (lines 13–16) *better* common subsumers L_2 (line 15), by solving the system reported hereafter: $\{C_1 \sqsubseteq L_2; C_2 \sqsubseteq L_2; L_1 \not\sqsubseteq L_2\}$ (lines 22–24 or 32–34, depending on the adopted \mathcal{DL}). When no common subsumer L_n such that $L_{n-1} \not\sqsubseteq L_n$ exists, L_{n-1} is returned as best (Least) Common Subsumer (line 17).

The incremental construction of candidate better common subsumers L_2 exploits a predicate, namely *decorate*, which makes the common subsumer at hand L_1 more specific by appending fresh variables to it at every nesting level (lines 18–20). We notice that, even though different clauses are needed to check if L_2 is *better* than L_1 in \mathcal{EL} (lines 21–24) and \mathcal{ALN} (lines 25–34), such a distinction is only due to efficiency reasons: *subs_aln* needs two parameters more than *subs_el* and the adoption of a logic-independent unique *better_lcs* would force *subs_el* to work less efficiently with such two parameters, even though instantiated to anonymous variables. By the way, the reader can notice that the solving strategy underlying *better* is shared by both characterizations.

We observe also that all predicates invoked but not listed in the previously reported excerpt belong to one of the imported modules. In particular, *subs_el* and *sub_aln* modules provide the related logic-dependent subsumption programs, listed in Section 4.1. The other imported modules, *i.e.*, *support_modules* and *normalization*, include clauses crucial for the problem solution, but outside the core solving algorithms.

Among the others, we underline the role of the logic-dependent predicate *manage_concept* (see lines 9–10), which manipulates input concepts to make them ready for subsumption in the adopted DL : in the case of \mathcal{EL} , simple list manipulation operations are performed, while in the case of \mathcal{ALN} , such a predicate starts the process of normalization of input concepts: concepts are reduced in CCNF and both possible clashes and inherent subsumption relationships between number restrictions are identified.

4.1 Subsumption

Both in \mathcal{EL} and in \mathcal{ALN} , the subsumption algorithm takes as input concept descriptions written as conjunctions, formalized as Prolog lists. We recall that in \mathcal{ALN} such Prolog lists result from a pre-processing step of problem inputs: before checking for subsumption, concepts are manipulated to identify and manage possible clashes, number restrictions relationships and reduction in CCNF.

Given two concept descriptions C_1 and C_2 in a DL \mathcal{DL} , in order to prove whether C_2 subsumes C_1 (formally $C_1 \sqsubseteq C_2$), the algorithm recursively searches, for each member of the list related to C_2 , at least one subsumed member in the list represent-

ing $C1$. In other words, the whole subsumption check mechanism reverts to a one-one comparison between list members (or, more appropriately, conjuncts).

With ground lists, the proposed subsumption predicate just returns boolean answers showing check results. Nevertheless, we notice that conjuncts in input concept descriptions may also include concept variables: when lists are not ground, subsumption is inverted to exhibit possible variables substitutions making subsumption between list members true. The mechanism exploits Prolog built-in unification.

As hinted before, the overall mechanism solving subsumption is shared by both implementations and is built on one-to-one comparison of list members, either ground or variables.

Clauses comparing single list members exploit syntactical features of the DL at hand to either check subsumption between ground elements or unify variables to values making subsumption true. In the following, the Prolog code for such clauses in both implementations is provided.

Subsumption in \mathcal{EL}

```

1 subsomeone(A, A, BL, BLF):-
2     literal(A),
3     not(member(A, BL)),
4     append([A], BL, BLF).
5 subsomeone(some(R,C1), some(R, C2N), BL, BLF):-
6     subs_el(C1, C2),
7     normalization_top(C2, C2N),
8     not(subs_el(BL,some(R,C2N))),
9     append([some(R,C2N)],BL,BLF) .
10 subsomeone(Any, top, [], [top]).

11 subsomeoneground(A, A):- literal(A).
12 subsomeoneground(some(R,C1), some(R, C2)):-
13     subs_el(C1, C2).
14 subsomeoneground(_, top).

```

Subsumption in \mathcal{ALN}

```

1 subsomeone(bottom, _, _, _).
2 subsomeone(_, top, _, _).
3 subsomeone(A, A, _, _):- literal(A).
4 subsomeone(atleast(N,R), atleast(M, R), _, _):-
5     integer(N),
6     integer(M),
7     >=(N, M).
8 subsomeone(atleast(N,R), atleast(M, R),_, _):-
9     var(M),
10     geqpositive(N,M).
11 subsomeone(atleast(N,R), atleast(M, R), MaxL, _):-

```



```

12     var (N) ,
13     integer (M) ,
14     integer (MaxL) ,
15     leqBounded (M,N,MaxL) .
16 subsoneone (atmost (N,R) , atmost (M, R) ,_, _ ) :-
17     integer (N) ,
18     integer (M) ,
19     ! ,
20     =< (N,M) .
21 subsoneone (atmost (N,R) , atmost (M, R) ,_, MaxM) :-
22     var (M) ,
23     integer (MaxM) ,
24     leqBounded (N, M, MaxM) .
25 subsoneone (atmost (N,R) , atmost (M, R) ,_, _ ) :-
26     var (N) ,
27     geqpositive (M,N) .
28 subsoneone (_, all (R, top) , MaxL, MaxM) :-
29     nonvar (R) .
30 subsoneone (all (R,C1) , all (R, C2) , MaxL, MaxM) :-
31     subsoneone (C1, C2, MaxL, MaxM) .
32 subsoneone (atmost (0, R) , all (R, C) , _, _) .

```

5 Querying the Prototype

In order to show our prototype working mode, we refer to the examples in the following, related to the three computational problems and the two DLs investigated in the paper:

1. $L = LCS(C_1, C_2)$, $DL = \mathcal{EL}$
 $C_1 = \exists R.(A \sqcap B) \sqcap \exists R.(C \sqcap D)$;
 $C_2 = \exists R.(A \sqcap C) \sqcap \exists R.(B \sqcap D)$
2. $L = LCS(C_1, C_2)$, $DL = \mathcal{ALN}$
 $C_1 = (\geq 3 G) \sqcap (\leq 7 S) \sqcap \forall R.(\leq 2 M)$;
 $C_2 = (\geq 4 G) \sqcap (\leq 3 S) \sqcap \forall R.U$
3. $L = DIFF(C_1, C_2)$, $DL = \mathcal{EL}$
 $C_1 = A \sqcap B \sqcap \exists R.(C \sqcap D \sqcap \exists S.(H \sqcap J))$;
 $C_2 = A \sqcap B \sqcap \exists R.(\exists S.H)$
4. $L = DIFF(C_1, C_2)$, $DL = \mathcal{ALN}$
 $C_1 = A \sqcap \forall R.(B \sqcap (\leq 4 S)) \sqcap (\leq 0 T)$;
 $C_2 = A \sqcap \forall R.(\leq 4 S) \sqcap \forall T.(D \sqcap \forall U.E \sqcap (\geq 2 V))$
5. $L = ABD(C_1, C_2)$, $DL = \mathcal{EL}$
 $C_1 = \exists R.(\exists S.H)$;
 $C_2 = A \sqcap B \sqcap \exists R.(C \sqcap D \sqcap \exists S.(H \sqcap J))$
6. $L = ABD(C_1, C_2)$, $DL = \mathcal{ALN}$
 $C_1 = (\geq 2 R) \sqcap \forall R.\neg A \sqcap B, \sqcap C$;
 $C_2 = B \sqcap (\geq 3 R)$

Table 1 shows the Prolog formalization and the results for the queries corresponding to the problems above. We note that, when problems admit multiple solutions — as it is in

Table 1. Prolog Queries

Query	Formalization	Result
1	<i>problem(lcs, [some(r,[a,b]), some(r,[c,d])], [some(r,[a,c]), some(r,[b,d])], L, el)</i>	$L = [some(r,[a]), some(r,[b]), some(r,[c]), some(r,[d])]$
2	<i>problem(lcs, [atleast(3,g), atmost(7,s), all(r,atmost(2,m))], [atleast(4,g), atmost(3,s), all(r,u)], L, aln)</i>	$L = [atleast(3, g), atmost(7, s)]$
3	<i>problem(diff, [a,b, some(r, [c,d, some(s,[h,j])]), [a,b, some(r,[some(s, [h])]), L, el)</i>	$L = [some(r, [c, d, some(s, [h, j])])]$
4	<i>problem(diff, [a, all(r, [b, atmost(4, s)]), atmost(0, t)], [a, all(r, atmost(4, s)), all(t, [d,all(u, e), atleast(2,v)])], L, aln)</i>	$L = [atmost(0, t), all(r, b)]$
5	<i>problem(abd, [some(r,[some(s, [h])]), [a,b, some(r,[c,d, some(s,[h,j])]), L, el)</i>	$L = [a,b, some(r, [c, d, some(s, [h, j])])]$
6	<i>problem(abd, [atleast(2,r),all(r,neg(a)), b, c],[b, atleast(3, r)],L, aln)</i>	$L = [atleast(3, r)]$

Concept Abduction and Concept Difference—the system stops searching for solutions when the first one is retrieved. As pointed out since the introduction, our prototype is still inefficient at this stage: all results in Table 1 need a few seconds to be returned, and Query 4, which is the most complex one, asks for about 10 seconds.³

6 Discussion and Future Work

Motivated by the need to unify as much as possible the process of solving non-standard reasoning problems, we proposed a general framework dealing with several inferences according to a logic-independent strategy, to be further specialized to cope with the DL adopted to model the problem at hand.

The paper presents a modular Logic Programming prototype system demonstrating the feasibility of the proposed strategy for Least Common Subsumer, Concept Difference and Concept Abduction computation in \mathcal{EL} and \mathcal{ALN} .

The extension of the approach to different DL sublanguages, and the implementation, for each investigated DL, of further non-standard reasoning services in the prototype is part of our future work, together with the improvement of system efficiency.

Of course, the approach presented in this paper has some theoretical limitations. Namely, the use of structural subsumption limits this approach to DLs for which structural subsumption is complete. For more expressive DLs, the fixpoint mechanism could

³ Using an Intel(R) Core(TM) i5 CPU 2.40 GHz with 4.00 GB RAM.

still be exploited, but using some higher-order tableaux methods that are still to be defined and whose correctness and termination should be proved.

References

1. Baader, F.: Least common subsumers and most specific concepts in a description logic with existential restrictions and terminological cycles. In: Proc. of IJCAI 2003. pp. 319–324 (2003)
2. Baader, F., Küsters, R., Borgida, A., McGuinness, D.L.: Matching in description logics. *J. of Log. and Comp.* 9(3), 411–447 (1999)
3. Baader, F., Küsters, R., Molitor, R.: Rewriting concepts using terminologies. In: Proc. of KR 2000. pp. 297–308 (2000)
4. Baader, F., Morawska, B.: Unification in the description logic \mathcal{EL} . *Logical Methods in Computer Science* 6(3) (2010)
5. Baader, F., Narendran, P.: Unification of concept terms in description logics. *J. of Symbolic Computation* 31, 277–305 (2001)
6. Baader, F., Sertkaya, B.: Usability issues in description logic knowledge base completion. In: ICFCA-2009. pp. 1–21 (2009)
7. Baader, F., Sertkaya, B., Turhan, A.Y.: Computing the least common subsumer w.r.t. a background terminology. *J. of Appl. Log.* 5(3), 392–420 (2007)
8. Borgida, A., Walsh, T., Hirsh, H.: Towards measuring similarity in description logics. In: Proc. of DL 2005 (2005)
9. Cohen, W., Borgida, A., Hirsh, H.: Computing least common subsumers in description logics. In: Rosenbloom, P., Szolovits, P. (eds.) Proc. of AAAI'92. pp. 754–761. AAAI Press, Menlo Park, California (1992)
10. Colucci, S., Di Noia, T., Di Sciascio, E., Donini, F.M., Ragone, A.: A unified framework for non-standard reasoning services in description logics. In: Proc. of ECAI 2010. pp. 479–484. Lisbon, Portugal, August 16-20 (2010)
11. Di Noia, T., Di Sciascio, E., Donini, F.M.: Semantic matchmaking as non-monotonic reasoning: A description logic approach. *J. of Artificial Intell. Res.* 29, 269–307 (2007)
12. Di Noia, T., Di Sciascio, E., Donini, F.M., Mongiello, M.: Abductive matchmaking using description logics. In: Proc. of IJCAI 2003. pp. 337–342 (2003)
13. Kazakov, Y., Krötzsch, M., Simancik, F.: Concurrent classification of \mathcal{EL} ontologies. In: International Semantic Web Conference (1). pp. 305–320 (2011)
14. Konev, B., Walther, D., Wolter, F.: Forgetting and uniform interpolation in large-scale description logic terminologies. In: Proc. of IJCAI 2009. pp. 830–835. Morgan Kaufmann Publishers Inc., San Francisco, CA, USA (2009), <http://dl.acm.org/citation.cfm?id=1661445.1661577>
15. Lecue, F., Kotoulas, S., Aonghusa, P.M.: Capturing the pulse of cities: A robust stream data reasoning approach. Position paper, IBM Research, Smarter Cities Technology Centre, Dublin, Ireland (2011), wiki.planet-data.eu
16. McGuinness, D.L., Borgida, A.: Explaining subsumption in description logics. In: Proc. of IJCAI'95. pp. 816–821 (1995)
17. Nikitina, N.: Uniform interpolation in general \mathcal{EL} terminologies. Techreport, Institut AIFB, KIT, Karlsruhe (Mai 2011)
18. Schlobach, S.: Explaining subsumption by optimal interpolation. In: Proc. of JELIA'2004. pp. 413–425 (2004)
19. Teege, G.: Making the difference: A subtraction operation for description logics. In: Proc. of KR'94. pp. 540–550 (1994)